

Sigma Industrial Automation, Inc.

5450 FM 1103
Cibolo, TX 78108

3 1/4 LB CUT CHICKEN 8PC, 14HD
20 HD, LQ/SP BRST/WING

14501

KEEP REFRIGERATED



019000000014501832020021341100081421512271413767

NET WT.
LB.

21.34



893072001132

08/14/08
LOT 1

To you this is just a label.
To us it is your data, production, inventory and yield.



Scanning



Computers

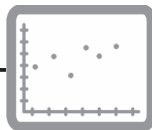

SPC



Labeling



Detection



Consulting



HACCP

Product tracking
Traceability and Quality Assurance
Data Collection Systems



NTEP - Pack out/Reject system

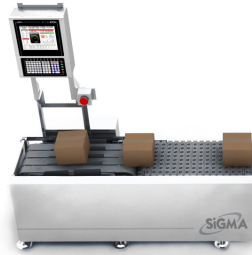

Calculate giveaway in real time and in both dollars and percent!

AS-10 LABELpaq system



Manual tote/case system

All data is sent to an open database and is viewed by our Encompass.net desktop.

| Order No | Date Sched... | SKU | SKU Name | Order... | Line... | Alarm... | Ready... | Date To... | Invent |
|----------|---------------|--------|--------------------------|----------|---------|----------|----------|------------|--------|
| 287 | 10/14/2003 | | | | | | | | |
| | | 000533 | CS,CHICKEN PAW,4/SKG,FRZ | 240 | 240 | 5 | 240 | | |
| | | 000697 | CP,CUT WINGS,40# ICE | 135 | 145 | 0 | 145 | | |
| | | 720871 | SPLIT BREASTS (WIP) | 150 | 95 | 5 | 64 | | |
| | | 3 | | 525 | 480 | 10 | 449 | | |

| SKU | SKU Name | Mfg ID | UPPER_LIMIT | NOMINAL | LOWER_LIMIT | LBL_FIXED | US |
|--------|----------------------|--------|-------------|---------|-------------|-----------|----|
| 710304 | WOG COMBO FOR REW... | 75632 | 60 | | 10 | 0 | 4 |
| 710306 | WOGS (WIP) | 75632 | 60 | | 10 | 0 | 2 |
| 719200 | POPEYES WOG (WIP) | 75632 | 60 | | 10 | 0 | 2 |
| 720871 | SPLIT BREASTS (WIP) | 75632 | 60 | | 10 | 1 | 1 |

Print and apply

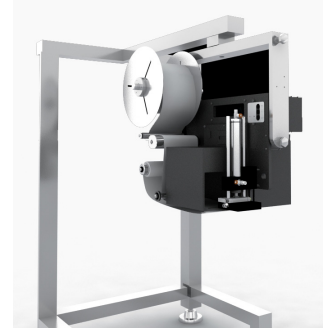

Side tamp, corner wrap or top apply

Weigh - Price Label



WP series optional bottom apply coupon applicators

- ✓ All systems powered by the same software, our LABELpaq
- ✓ Over 1,500 labeling systems in place
- ✓ Uses open database
- ✓ Manages orders
- ✓ Interfaces with our scanpaq.net tracking system
- ✓ Expert design and installation service

SigmaCONNECT
all systems networked.
11111110101000000

Power tools for your plant!

SAN ANTONIO, TX
T:210-659-5000
5450 Fm 1103
Cibolo, TX 78108

Sigma Industrial Automation

www.sigma-usa.com
mail@sigma-usa.com

SPRINGDALE, AR
T:479-283-4500
717 Carlton St.
Springdale, AR 72762